

A CERTIFICATE BY THE ENGINEER  
STATE OF TEXAS  
COUNTY OF BRAZOS

I, MICHAEL R. MCCLURE, Registered Professional Engineer, No. 38720, in the State of Texas, hereby certify that proper engineering consideration has been given this plat.

Michael R. McClure  
Registered Professional Engineer

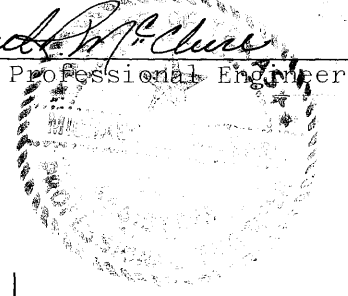

CERTIFICATION BY THE COUNTY CLERK:  
STATE OF TEXAS  
COUNTY OF BRAZOS

I, Frank Borotci, County Clerk in and for the said County do hereby certify that this plat together with its certificates of authentication was filed for record in my office the 15 day of November, 1980, in the Deed Records of Brazos County, Texas, Volume 467, Page 407.

Frank Borotci  
County Clerk, Brazos County, Texas

CERTIFICATION BY THE DIRECTOR OF PLANNING  
I, the Undersigned, Director of Planning of the City of Bryan hereby certify that the plat conforms to the City master plan, major street plan, land use plan, and the standards and specifications set forth in the Ordinance.

Hubert Nelson  
Director of Planning, Bryan, Texas

APPROVAL OF THE PLANNING COMMISSION  
I, P.D. WILLIAMSON, Chairman of the City Planning Commission of the City of Bryan, State of Texas, hereby certify that the attached plat was duly filed for approval with the City Planning Commission of the City of Bryan on the 17 day of August, 1980 and same was duly approved on the 24 day of September, 1980 by said Commission.

P.D. Williamson  
Chairman, City Planning Commission Bryan, Texas

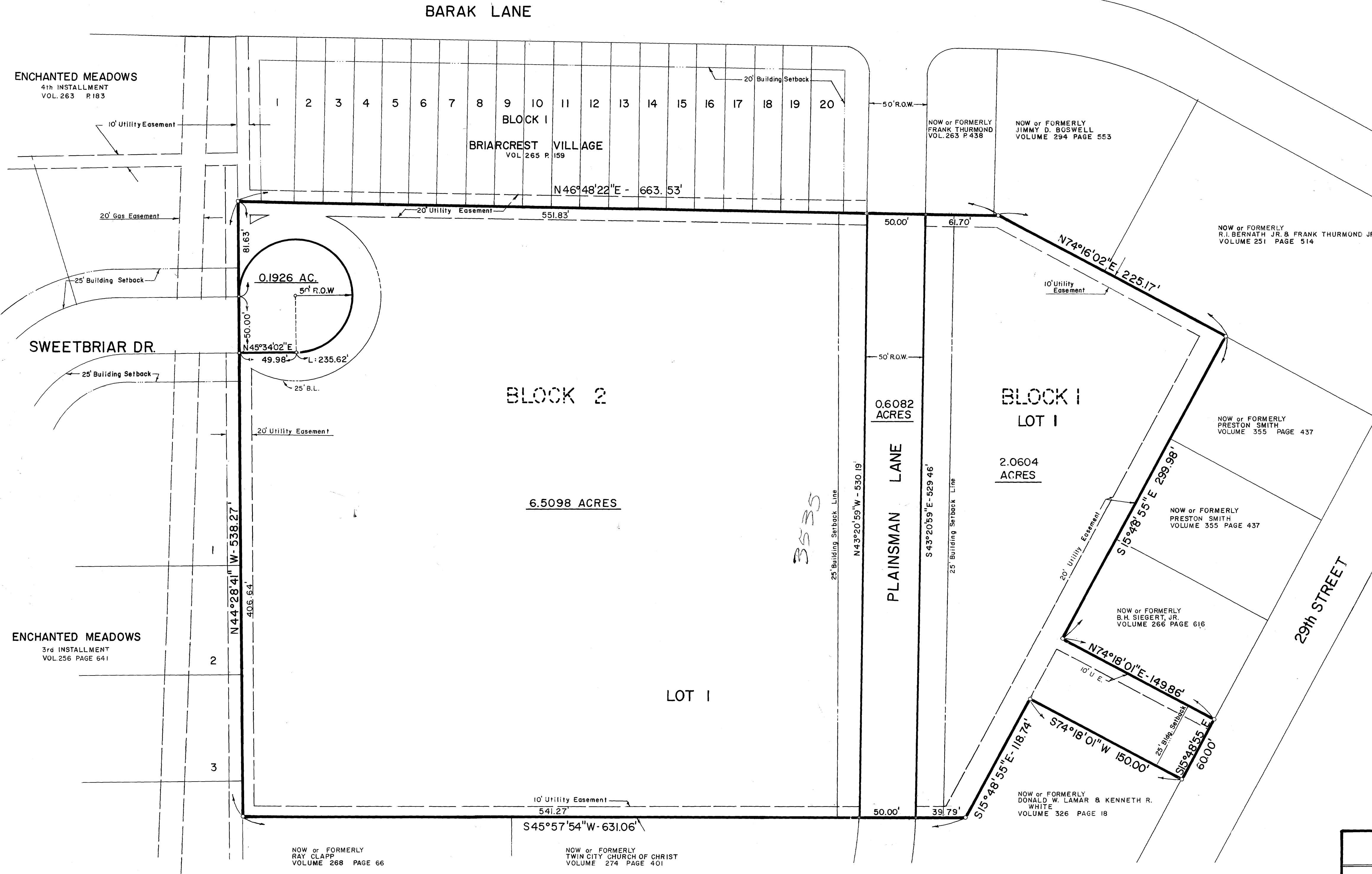
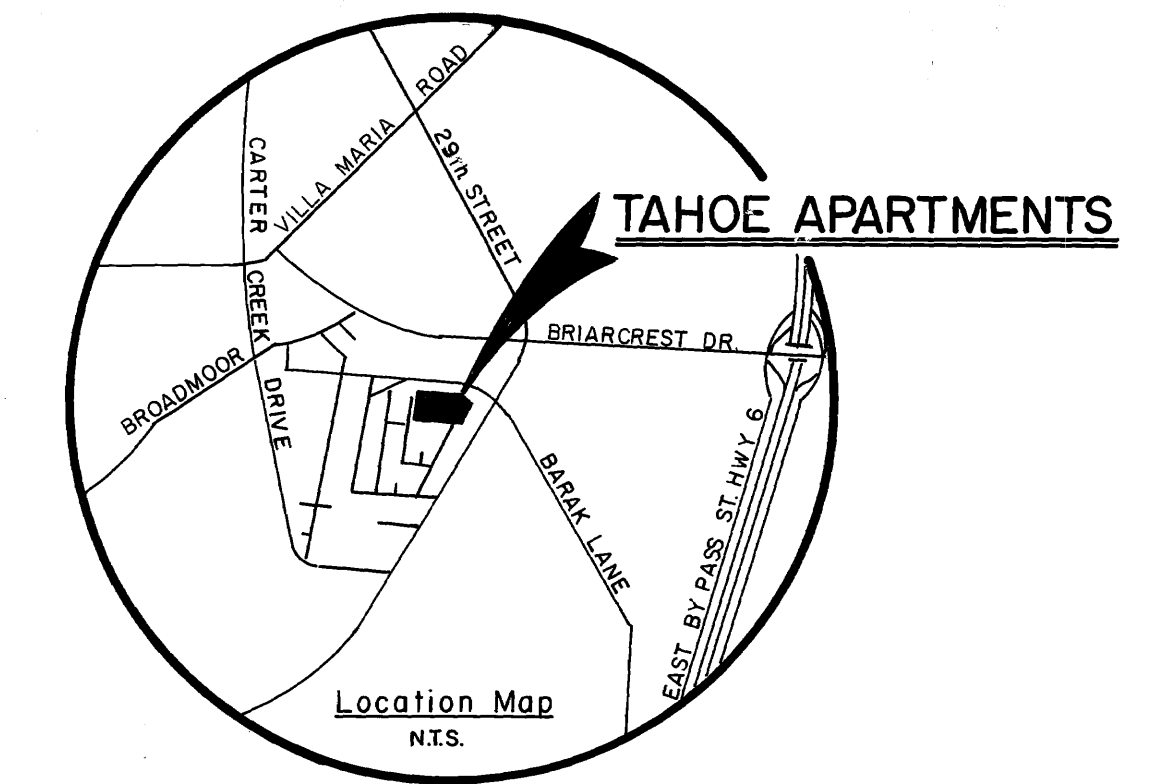
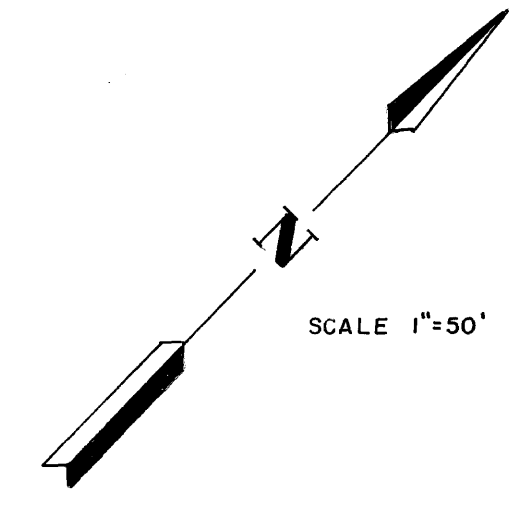

on lawbase  
WD  
5/2/01

OWNER'S ACKNOWLEDGMENTS AND DEDICATIONS:

STATE OF TEXAS  
COUNTY OF BRAZOS

X (we), M.G. Perkins & B.T. Yager, Owner(s) and Developer(s) of the land shown on this plat, as conveyed in the Deed Records of Brazos County, Texas, Volume 302, Page 14, and designated herein as the Tahoe Apartments Subdivision to the City of Bryan, Texas, and whose name is subscribed hereto, hereby dedicate to the use of the public forever all streets, alleys, parks, water courses, drains, easements and public places thereon shown for the purpose and consideration therein expressed.

M.G. Perkins B.T. Yager  
Owner

Notary  
Lien Holder Approval

CERTIFICATION OF THE SURVEYOR  
STATE OF TEXAS  
COUNTY OF BRAZOS

I, Donald D. Garrett, Registered Public Surveyor, No. 2972, in the State of Texas, hereby certify that this plat is true and correct and was prepared from an actual survey of the property made under my supervision on the ground.

Donald D. Garrett  
Registered Public Surveyor

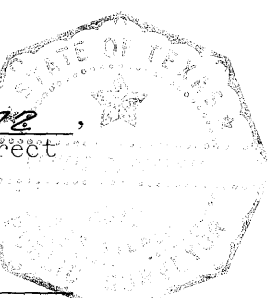

STATE OF TEXAS  
COUNTY OF BRAZOS

Before me, the undersigned authority, on this day personally appeared M.G. Perkins & B.T. Yager, known to me to be the persons whose names are subscribed to the foregoing instrument, and acknowledged to me that they executed the same for the purpose and consideration therein stated.

GIVEN under my hand and seal on this 29th day of September, 1980.

William B. Bunt  
Notary Public, Brazos County, Texas

FINAL PLAT

**TAHOE APARTMENTS**

RICHARD CARTER LEAGUE  
BRYAN, BRAZOS COUNTY, TEXAS

9371 ACRES

Scale 1"=50'

AUG, 1980

OWNER & DEVELOPER  
M. G. PERKINS & B. T. YAGER  
1106 TEXAS AVE  
BRYAN, TEXAS

ENGINEER & SURVEYOR  
GARRETT-McCLURE ENGINEERING  
1520 A CAVITT AVENUE  
P.O. BOX 4063  
BRYAN, TEXAS 77801

DEC 15 1980  
10001